

Schematic Diagram of JumboZ-1500 MANUAL STEERING

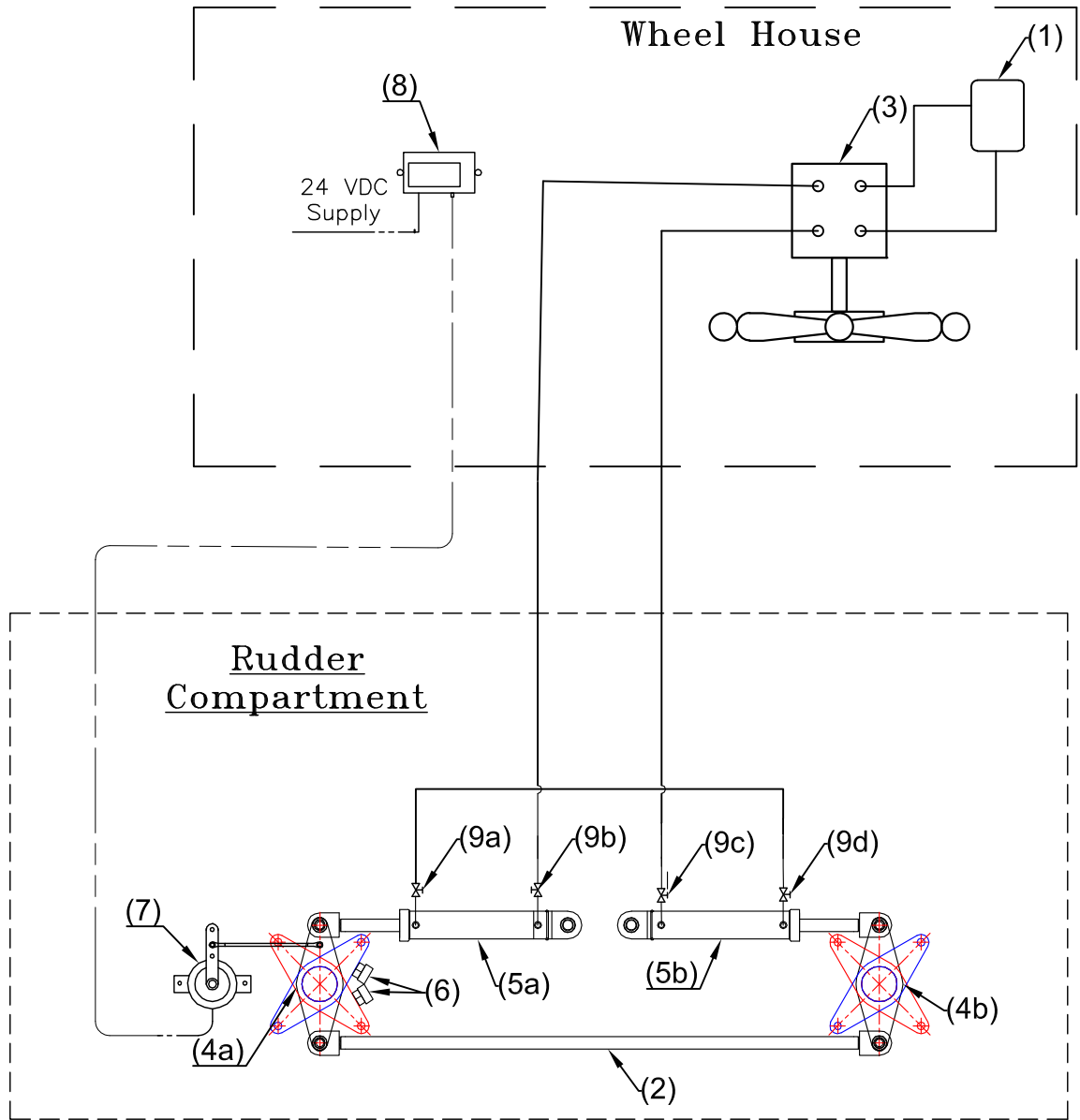

SPECIFICATIONS	
1.	Tiller Radius : 300mm.
2.	Pump Capacity:- Manual : 160CC/rev.
3.	HYD.ACTUATOR:- Ram : 45 mm x 2 Stroke : 440 mm.
4.	PIPE :- OD : 16mm. ID : 12MM.
5.	HOSE :- GRADE : R1 I.D : $\frac{1}{2}$ "

10a,10b	By-Pass Valve
9a,9b,9c,9d	Isolation Valve
8	Rudder Angle Indicator
7	Rudder Angle Sensor
6	Mechanical Stopper (Customer Supply)
5a,5b	Hyd. Actuator JumboZ-1500
4a,4b	Tiller Arm
3.	Main Steering Unit
2.	Connection Rod (Customer Supply)
1.	Oil Reservoir
Sl.no	Description

ITEM	SCALE	MATERIAL	VIEW	DRAWN	CHECKED
/	NTS	/		SRH	VUK
DESIGNATION			DWG NO	DATE	QTY
Schematic Diagram of JumboZ-1500M			MHS-1815B	23.07.2024	/
MAC • N • HOM SYSTEMS KOCHI - 20					